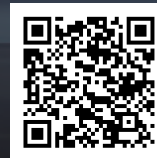

The JVC logo is displayed in a bold, red, sans-serif font in the top left corner of the advertisement.

D-ILA Projectors

DLA-NZ900, DLA-NZ800, DLA-NZ700, DLA-NZ500

The text 'D-ILA' is written in a large, white, bold, sans-serif font, centered horizontally and partially overlapping the two projector units.The text 'The ART of PROJECTION' is written in a white, sans-serif font, with 'The' and 'of' in a smaller size than 'ART' and 'PROJECTION'. Below it, the text 'A True Cinematic Experience' is written in a similar white, sans-serif font. The background features two black projectors with blue lens flares, set against a light blue gradient background.

*For more information on the new D-ILA projectors, scan or click
on the QR code to access the Official Website*

D-ILA The ART of PROJECTIONS



8K Home Theater Projectors

8K
e-shiftX



D-ILA home theater projectors in remarkable 8K resolution were made possible with over a quarter century of JVC engineering and technology. Discover the art of projection.



DLA-NZ900

Precision **D-ILA** *BLUESCENT*
Laser



100mm HQ Lens

Native contrast 150,000:1, Peak brightness: 3,300 lumens



DLA-NZ800

Precision **D-ILA** *BLUESCENT*
Laser



Native contrast 100,000:1, Peak brightness: 2,700 lumens

VISION A True Cinematic Experience

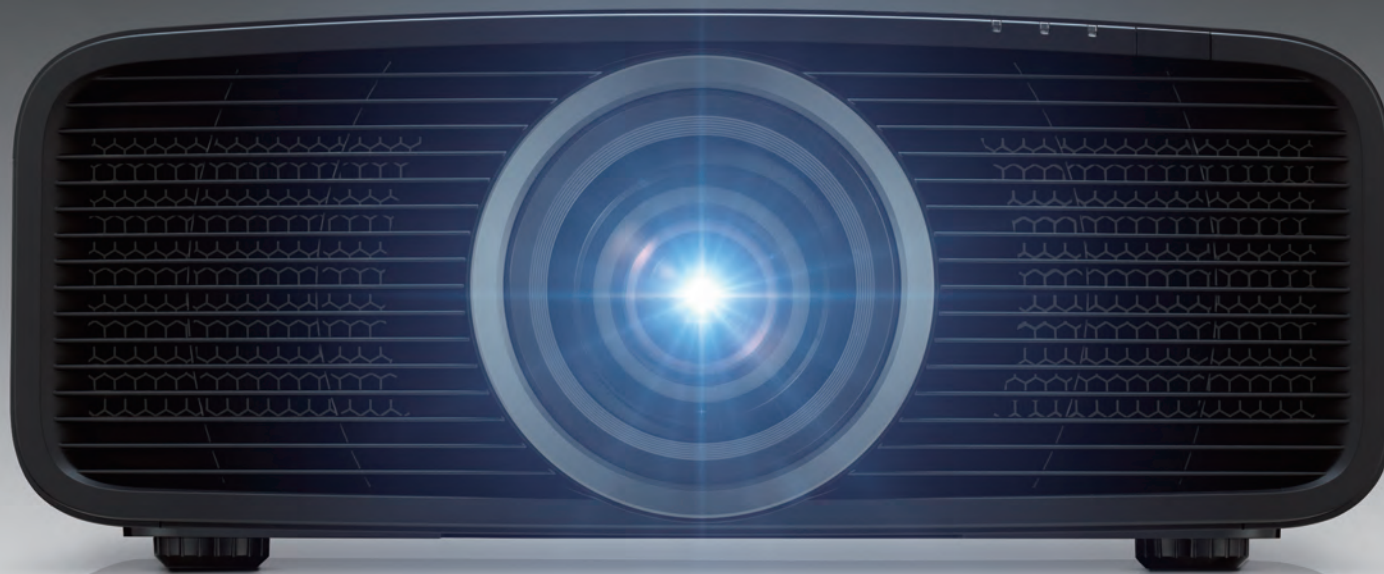

Native 4K Home Theater Projectors

4K

All new native 4K resolution models featuring the world's smallest body* satisfy a wider group of users with solid quality. Encounter a true cinematic experience.

*As of September 2024 for projectors featuring native 4K panel.



DLA-NZ700

Precision **D-ILA** *BLUEScent Laser*



Native contrast 80,000:1, Peak brightness: 2,300 lumens



DLA-NZ500

Precision **D-ILA** *BLUEScent Laser*



Native contrast 40,000:1, Peak brightness: 2,000 lumens

Exceptional Contrast, High Brightness, and Superior Resolution JVC Delivers Visual Excellence and Total Immersion

8K

8,192 x 4,320 pixels

Exceptional Contrast

Third-generation, Native 4K D-ILA Device

D-ILA device is the heart of projectors that plays an important role in projecting beautiful images. Device perfection continues to date – the third generation (Gen3) 0.69-inch native 4K D-ILA device has improved its alignment control of liquid crystals and enhanced the flatness of image pixels to offer 1.5-times* the native contrast ratio on the DLA-NZ900 compared to the Gen2 device.

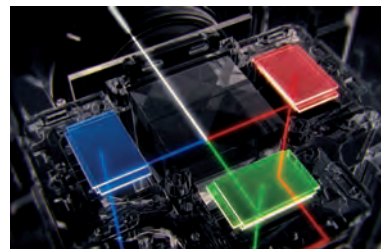

4K D-ILA

*1.25-times on the DLA-NZ800

Unparalleled Black Level and High Luminance

The DLA-NZ900 boasts the industry's highest native contrast of 150,000:1* with the Gen3 0.69-inch 4K D-ILA device and wire-grid optical engine, however in combination with the dynamic laser light control, which analyzes the incoming video signal to automatically control the amount of outgoing laser light, a dynamic contrast level of ∞ :1 (infinity to 1) can be achieved in scenes with pitch blackness by completely shutting off the light source.



Starry sky with a sense of contrast

*100,000:1 on the DLA-NZ800

High Brightness

Light Source for Exceptional Brightness

Another essential aspect of projectors lies in their light source. JVC's D-ILA projectors feature "BLU-Escent Laser" light source to achieve exceptional peak brightness of 3,300 lumens on the DLA-NZ900 and 2,700 lumens on the DLA-NZ800, both with longevity of 20,000 hours. Power efficiency improvements made on the BLU-Escent Laser also contributes to saving power.

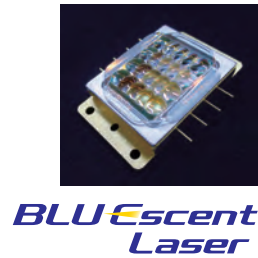

Superior Resolution

8K Resolution Display with Gen2 8K/e-shiftX

Combining a high-resolution display technology using 240Hz driver with 4-way multi-axis shift to flash the screen four times collectively, JVC's proprietary e-shift technology made significant improvements as the second generation 8K/e-shiftX. Featuring a new 8K scaling engine, the new Gen2 8K/e-shiftX drastically improves the projector's sharpness and detail across a wide range of content.



See how the native 4K image becomes sharper as if it is alive with the newest 8K/e-shiftX processing.

8K60p Input for 8K Content, 4K120p Input for Games and More

The 8K projectors support a variety of inputs including full 48Gbps 8K60p. By adopting LSIs developed with the latest technology, it is now possible to process four times the amount of information from input to D-ILA device instantly and correctly display 8K signals. As a result, users can enjoy stable high-quality 8K images at all times. Also, using 4K120p input with the Low Latency Mode further improves response to the player's rapid operations for displaying high frame-rate gaming content on large screens.



All-glass Lens System Designed for the 8K Projectors

The DLA-NZ900 is equipped with an 18-element, 16-group 100-mm all-glass lens* featuring a full aluminum lens barrel. To project high-resolution 8K images to every corner of the screen, the projector incorporates five ED lenses calibrated for differences in the R/G/B refractive index to reduce chromatic aberration and color fringing when lens shift kicks in to deliver precise reproduction of 4K- or 8K-resolution projection.

*The DLA-NZ800 features 17-element, 15-group 65-mm all-glass lens without ED lenses.

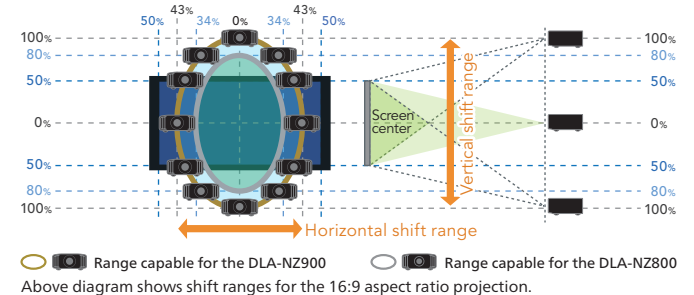

Refined Sleek Design, Native 4K, BLU-Escent Laser
Discover Your Next Cinematic Journey

Native **4K**
4,096 x 2,160 pixels

Compact Design

World's Smallest* Native 4K Projectors

Completely redesigned with a new chassis, optical units, lens system, and circuit boards, the DLA-NZ700 and NZ500 are the world's smallest native 4K projectors*. While maintaining a small footprint, these models incorporate JVC's proprietary BLU-Escent laser light source and native 4K devices found on the DLA-NZ900 and NZ800. The horizontal grille on the front panel expresses the center lens in a symbolic manner, while the rounded corners of the body emphasize user-friendliness.

*As of September 2024 for projectors featuring native 4K panel.



Superb Intake/Exhaust Layout

A straight cooling system that draws air in from the front and exhausts it out the back has been applied on the DLA-NZ700/NZ500 to emphasize compactness of the body, reduce the impact from heat on the projection screen and enable greater flexibility in installation.



Intake draws in air from the front and exhaust releases hot air from the rear.

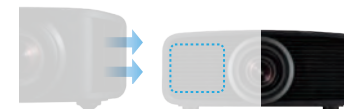

On the DLA-NZ900 and NZ800, exhaust releases air from the front towards the sides, whereas the newly designed straight cooling system draws air in from the front.

Native 4K Projection

Pixel Perfect Resolution with Native 4K Input and 4K D-ILA Device

Signals input via the 32Gbps 4K/60p HDMI terminal go through the third generation (Gen3) 0.69-inch native 4K D-ILA devices* to project full native 4K (4,096 x 2,160 pixels) resolution images on the screen with uniform brightness and more subtle blacks. With the combination of native 4K input and device, improved overall image quality can be achieved.

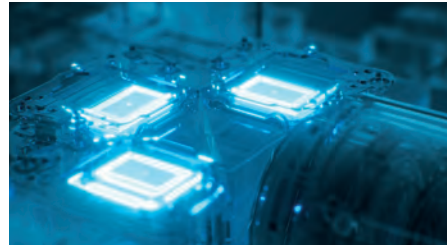

4K D-ILA

*Only on the DLA-NZ700

Unbeatable Black Level and High Luminance

Native contrast of 80,000:1* with dynamic contrast of ∞ :1 (infinity to 1) on the DLA-NZ700 is realized with the combination of the latest 0.69-inch native 4K D-ILA device with wire-grid optical engine and the BLU-Escent laser light source with dynamic laser light control. As a result, images brimming with reality can be achieved.



*DLA-NZ500 offers native contrast of 40,000:1.

New BLU-Escent Laser and 4K Lens System

BLU-Escent Laser for Remarkably Bright Images

JVC's proprietary "BLU-Escent Laser" light source designed exclusively for the new models is featured to achieve exceptional peak brightness of 2,300 lumens on the DLA-NZ700 and 2,000 lumens on the DLA-NZ500, both with longevity of 20,000 hours.

BLU-Escent Laser

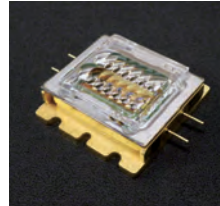

Controlling the Luminance on BLU-Escent Laser

Luminance of projectors equipped with BLU-Escent Laser can be finely adjusted according to the environment and preference using the Light Source Control with a total of 101 (0 – 100) luminance control steps.

101 luminance control steps (0 - 100 steps)

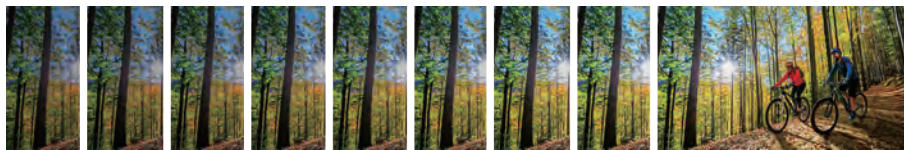

0 ← → 100

New Fully Motorized 4K Lens

The newly introduced compact projectors feature native 4K lens with a 15-element, 11-group, 80-mm lens with motorized focus, zoom, and shift for faithful reproduction of distortion-free, high-resolution native 4K images. In addition to a wide lens shift range of 70% vertical and 28% horizontal, these projectors are equipped with a 1.6x zoom that enables a projection distance of 3 meters at 100 inches, making these flexible for a variety of installation environments without sacrificing image quality. Its Lens Memory function comes in handy when switching between conventional 16:9- and cinemascope-sized screens.

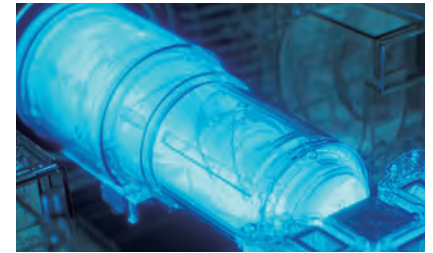

15-element, 11-group
80-mm lens

80mm



Lens shift function:
70 % vertical, 28 % horizontal

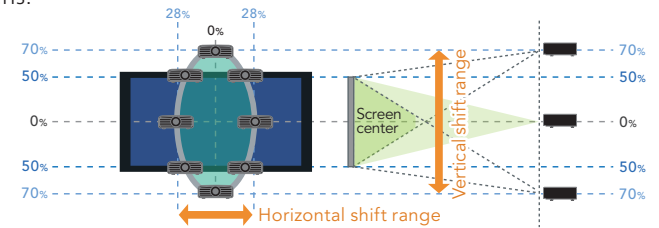

Above diagram shows shift ranges for the 16:9 aspect ratio projection.

Enjoy HDR Content to Its Fullest

HDR Drastically Improves Expressive Power of Images

When it comes to reproducing the rich video information of HDR content, rely on the new D-ILA projectors as these models support all HDR formats including HDR10 for Blu-ray and streaming, HLG for broadcasting, and the HDR10+ with dynamic metadata compatibility. The projectors' improvements for higher brightness and contrast have helped to achieve a wider dynamic range, allowing users to enjoy an immersive experience with HDR images full of reality.



Original Image



Frame Adapt HDR (Conventional)



Frame Adapt HDR Generation 2

MOVIE A



Gen2 Frame Adapt HDR Function

The Gen2 Frame Adapt HDR function's latest proprietary algorithm instantaneously analyzes the maximum brightness of an HDR10 content per scene or frame and performs real-time tone mapping to optimal dynamic range for high-definition video projection. The proprietary algorithm's improved tone curve selection also reproduces HDR images with a wider dynamic range that are brighter and more colorful.

DML (Display Mastering Luminance) for Better HDR Experience

DML (Max Display Mastering Luminance) metadata, which represents the nit level of the professional monitor used to grade the movie to the director's standards, is used to set the dynamic range of the title for improved HDR tone mapping. Both DML and MaxCLL values are used for the HDR levels.

Vivid Reproduction of HDR Sources Containing Wide Color Gamut

Even when HDR content using a wide color gamut equivalent to BT.709 and DCI-P3* is projected on these projectors, the original cinema filter combined with the BLU-Escent Laser work together to reproduce rich colors, such as the gradations of the sky and ocean, the contrast of red roses, or a row of fresh green trees.

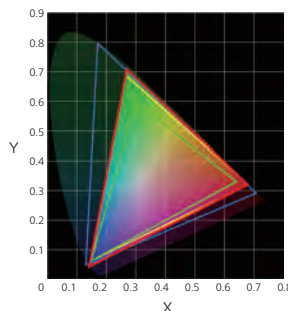

* The DLA-NZ500 supports 100% sRGB.

— DLA-NZ900/NZ800/NZ700 — BT.709 (sRGB) — DCI — BT.2020

Deeper Blacks for Richer Gradation

The new Deep Black Tone Control on the Gen2 Frame Adapt HDR with a new algorithm further subdues tones in dark areas to achieve more realistic darkness. This function maximizes the dynamic range of the new-generation 4K D-ILA devices and delivers images with more contrast than ever before. Scenes with light and dark shades such as nightscapes can be projected with greater realism.



Conventional



New Deep Black Tone Control

Projecting the Content More Beautifully and Faithfully

Picture Mode “Vivid”

To reproduce content with a narrow dynamic range in more saturated colors, conventional Natural mode has been improved to the new “Vivid” mode. This mode is excellent for projecting classic SDR works with greater vividness that are yet popular in streaming content and gaming CGs.



Conventional Natural mode



New “Vivid” mode



FILMMAKER MODE™

Recreating the Creator’s Original Intentions

FILMMAKER MODE™ was developed by the UHD Alliance with the aim of faithfully reproducing the filmmakers’ intentions in the home. When using the mode, picture quality adjustments such as frame interpolation and noise reduction are turned off, and the color temperature is set to D65 (6500K), allowing users to enjoy movies and documentaries with picture quality that is faithful to the original master.

Clear Motion Drive

Clear Motion Drive allows viewers to enjoy smoother and clearer images. With the DLA-NZ900/NZ800 when inputting signals at 24/25/30/50/60Hz, compensation accuracy has been improved in the periphery of intersecting objects.



Clear Motion Drive: Off



Clear Motion Drive: On

Adjustments and Installation

- Ultra-high Contrast Optics not only contributes to achieving high optical brightness, but also suppresses the return of unnecessary light to the projection screen for clear and colorful images.
- Auto Calibration function that uses an optical sensor with proprietary software* optimizing all essential elements found in the image, including color balance, gamma characteristics, etc. that change according to installation and usage conditions.

*Optional optical sensor and proprietary software, PC, and LAN cable are required to perform auto calibration function.

- Installation Mode: The DLA-NZ900 and NZ800 models allow user to centrally manage 8 settings such as Lens Control, and Pixel Adjustment. A total of 10 different mode settings can be named, stored and called up. On the DLA-NZ700 and NZ500 models, up to 5 settings including Lens Memory, Pixel Adjustment, and Screen Mask can be stored and called up.
- More than 200 Screen Adjustment modes can be used to correct imbalances caused by screen characteristics.



Scan or click on the QR code to access the Screen Adjustment Mode Table



● Specifications

GENERAL		DLA-NZ900	DLA-NZ800	DLA-NZ700	DLA-NZ500
Device		0.69-inch Native 4K D-ILA Device (4,096 x 2,160) x3			
Display Resolution		8,192 x 4,320 (Gen2 8K/e-shiftX)		4,096 x 2,160 (Native)	
Lens	Type	x2 motorized zoom & focus, all-glass lens		x1.6 motorized zoom & focus, native 4K lens	
	Diameter	100 mm	65 mm	80 mm	
Lens Shift (motorized in 16:9 aspect ratio)	Vertical	±100%	±80%	±70%	
	Horizontal	±43%	±34%	±28%	
Projection Display Size (diagonal)		60 inch – 300 inch		60 inch – 200 inch	
Light Source		BLU-Escent Laser diode			
Brightness		3,300 lm	2,700 lm	2,300 lm	2,000 lm
Contrast Ratio	Dynamic	∞:1			
	Native	150,000:1	100,000:1	80,000:1	40,000:1
Cinema Filter (Color Gamut)		DCI 98%/BT.2020 73%			sRGB 100%
Input Terminal	HDMI	2 (48 Gbps/HDCP 2.3, no CEC support)		2 (32 Gbps/HDCP 2.3, no CEC support)	
Output Terminal	TRIGGER	1 (Mini Jack, DC 12 V/100 mA)		–	–
	3D SYNCHRO	1 (Mini Din 3-pin)		–	–
Control Terminal	RS 232C	1 (D-sub 9pin)		–	–
	LAN	1 (RJ45)			
Service Terminal	SERVICE	1 (USB Type A) for firmware update and backing up settings			
Power Consumption	Projector in Use	440 W		280W	
	Eco-mode Standby	0.3 W			
	Standby	1.5 W			
Fan Noise		24 dB (LD power at minimum)		23 dB (LD power at minimum)	
Power Requirement		AC 100-240V, 50/60Hz			
Dimensions (W x H x D, including feet)		19-11/16 in x 9-7/32 in x 20-13/16 in / 500 mm x 234 mm x 528 mm	19-11/16 in x 9-7/32 in x 19-29/32 in / 500 mm x 234 mm x 505 mm	17-23/32 in x 7-5/32 in x 18-7/8 in / 450 mm x 181 mm x 479 mm	
Weight (net)		55.7 lb. / 25.3 kg	50.9 lb. / 23.1 kg	32.6 lb. / 14.8 kg	32.2 lb. / 14.6 kg

FEATURES		DLA-NZ900	DLA-NZ800	DLA-NZ700	DLA-NZ500
Max Input		80K60p and 4K120p		4K60p	
Light Source Control by Slider Adjustment		101 steps			
Ultra-High Contrast Optics		•			
HDR	HDR10+	•			
	HLG	•			
	Mastering Info Display	• (Max CLL/Max FALL/DML)			
	Frame Adapt HDR Gen2	•			
	Deep Black Tone Control	•			
	Theater Optimizer	•	–	–	–
“Vivid” Mode for SDR		•			
FILMMAKER MODE™		•			
3D Support		•			
Clear Motion Drive		•			
Motion Enhance		•			
Low Latency Mode		•			
Auto Calibration		•			
Installation Mode		• (max. 10 memories)		• (max. 5 memories)	
ISFccc Certification		•			
Screen Adjustment Mode		•			
USB Back-up		•			

Note: Values are typical. Depends on the projector setting conditions and usage environment.

● External Dimensions

Unit: inches (mm)

DLA-NZ900

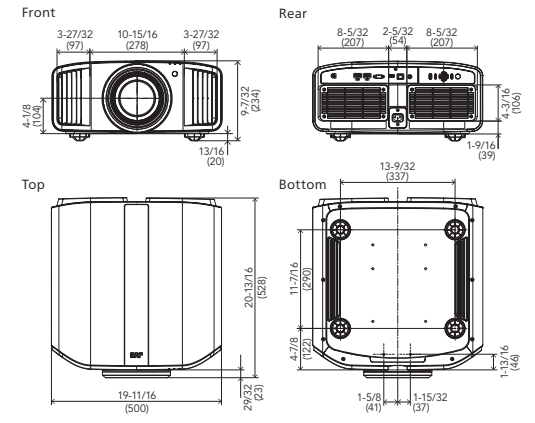

DLA-NZ800

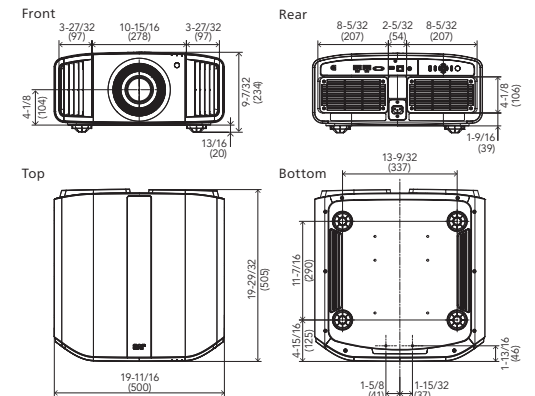

DLA-NZ700/NZ500

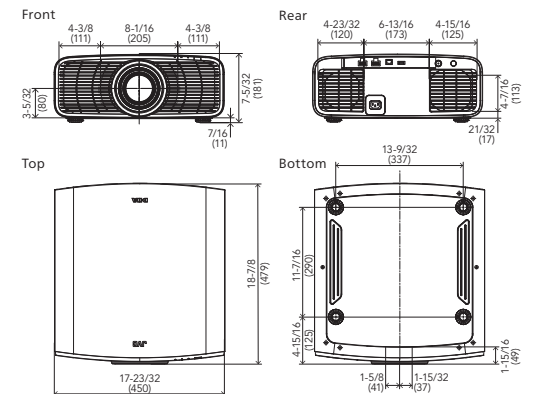

● Projection Distance Chart

DLA-NZ900

Screen diagonal (inch)	Screen size aspect ratio: 16:9				Screen size aspect ratio: 2.4:1 (Cinematic)			
	Screen size		Projection distance		Screen size		Projection distance	
	Width (in / mm)	Height (in / mm)	Wide (in / m)	Tele (in / m)	Width (in / mm)	Height (in / mm)	Wide (in / m)	Tele (in / m)
60	52.3 / 1,328	29.4 / 747	69.1 / 1.75	142.2 / 3.61	55.2 / 1,402	23.1 / 586	73.3 / 1.86	150.8 / 3.83
90	78.4 / 1,992	44.1 / 1,121	105.2 / 2.67	214.8 / 5.46	82.8 / 2,103	34.6 / 879	111.6 / 2.83	227.7 / 5.78
100	87.2 / 2,214	49.0 / 1,245	117.2 / 2.98	239.0 / 6.07	92.0 / 2,337	38.5 / 977	124.3 / 3.16	253.3 / 6.43
110	95.9 / 2,435	53.9 / 1,370	129.3 / 3.28	263.3 / 6.69	101.2 / 2,571	42.3 / 1,075	137.1 / 3.48	279.0 / 7.09
120	104.6 / 2,657	58.8 / 1,494	141.3 / 3.59	287.5 / 7.30	110.4 / 2,805	46.2 / 1,172	149.9 / 3.81	304.6 / 7.74
150	130.7 / 3,321	73.5 / 1,868	177.5 / 4.51	360.1 / 9.15	138.0 / 3,506	57.7 / 1,465	188.1 / 4.78	381.6 / 9.69
200	174.3 / 4,428	98.1 / 2,491	237.7 / 6.04	481.2 / 12.22	184.0 / 4,674	76.9 / 1,954	251.9 / 6.40	509.8 / 12.95
250	217.9 / 5,535	122.6 / 3,113	297.9 / 7.57	602.2 / 15.30	230.0 / 5,843	96.2 / 2,442	315.7 / 8.02	638.0 / 16.20
280	244.0 / 6,199	137.3 / 3,487	334.0 / 8.48	674.9 / 17.14	—	—	—	—

Note: Projection distances are design specifications, so there is ±5% variation.

DLA-NZ800

Screen diagonal (inch)	Screen size aspect ratio: 16:9				Screen size aspect ratio: 2.4:1 (Cinematic)			
	Screen size		Projection distance		Screen size		Projection distance	
	Width (in / mm)	Height (in / mm)	Wide (in / m)	Tele (in / m)	Width (in / mm)	Height (in / mm)	Wide (in / m)	Tele (in / m)
60	52.3 / 1,328	29.4 / 747	74.0 / 1.88	151.7 / 3.85	55.2 / 1,402	23.1 / 586	78.5 / 1.99	160.8 / 4.08
90	78.4 / 1,992	44.1 / 1,121	111.9 / 2.84	228.4 / 5.80	82.8 / 2,103	34.6 / 879	118.7 / 3.01	242.0 / 6.15
100	87.2 / 2,214	49.0 / 1,245	124.6 / 3.16	254.0 / 6.45	92.0 / 2,337	38.5 / 977	132.0 / 3.35	269.1 / 6.83
110	95.9 / 2,435	53.9 / 1,370	137.2 / 3.49	279.6 / 7.10	101.2 / 2,571	42.3 / 1,075	145.4 / 3.69	296.2 / 7.52
120	104.6 / 2,657	58.8 / 1,494	149.9 / 3.81	305.1 / 7.75	110.4 / 2,805	46.2 / 1,172	158.8 / 4.03	323.2 / 8.21
150	130.7 / 3,321	73.5 / 1,868	187.8 / 4.77	381.8 / 9.70	138.0 / 3,506	57.7 / 1,465	199.0 / 5.05	404.5 / 10.27
200	174.3 / 4,428	98.1 / 2,491	251.0 / 6.38	509.7 / 12.95	—	—	—	—

Note: Projection distances are design specifications, so there is ±5% variation.

DLA-NZ700/NZ500

Screen diagonal (inch)	Screen size aspect ratio: 16:9				Screen size aspect ratio: 2.4:1 (Cinematic)			
	Screen size		Projection distance		Screen size		Projection distance	
	Width (in / mm)	Height (in / mm)	Wide (in / m)	Tele (in / m)	Width (in / mm)	Height (in / mm)	Wide (in / m)	Tele (in / m)
60	52.3 / 1,328	29.4 / 747	69.6 / 1.77	112.4 / 2.85	55.4 / 1,407	23.1 / 586	73.8 / 1.87	119.1 / 3.03
90	78.4 / 1,992	44.1 / 1,121	105.3 / 2.68	169.6 / 4.31	83.1 / 2,110	34.6 / 879	111.7 / 2.84	179.7 / 4.56
100	87.2 / 2,214	49.0 / 1,245	117.3 / 2.98	188.6 / 4.79	92.3 / 2,345	38.5 / 977	124.3 / 3.16	199.9 / 5.08
110	95.9 / 2,435	53.9 / 1,370	129.2 / 3.28	207.7 / 5.28	101.5 / 2,579	42.3 / 1,075	136.9 / 3.48	220.1 / 5.59
120	104.6 / 2,657	58.8 / 1,494	141.1 / 3.58	226.8 / 5.76	110.8 / 2,814	46.2 / 1,172	149.6 / 3.80	240.3 / 6.10
150	130.7 / 3,321	73.5 / 1,868	176.9 / 4.49	284.0 / 7.21	138.5 / 3,517	57.7 / 1,465	187.5 / 4.76	300.9 / 7.64
200	174.3 / 4,428	98.1 / 2,491	236.5 / 6.01	379.3 / 9.63	184.6 / 4,689	76.9 / 1,954	250.6 / 6.37	401.8 / 10.21

Note: Projection distances are design specifications, so there is ±5% variation.

● Optional Accessory



PK-EM2

3D RF Emitter (paired with the PK-AG3)

Signal reaches to 10 meters. No IR signal interruption with other equipment. No limitation to the number of the glasses.

● Connectors

DLA-NZ900/NZ800

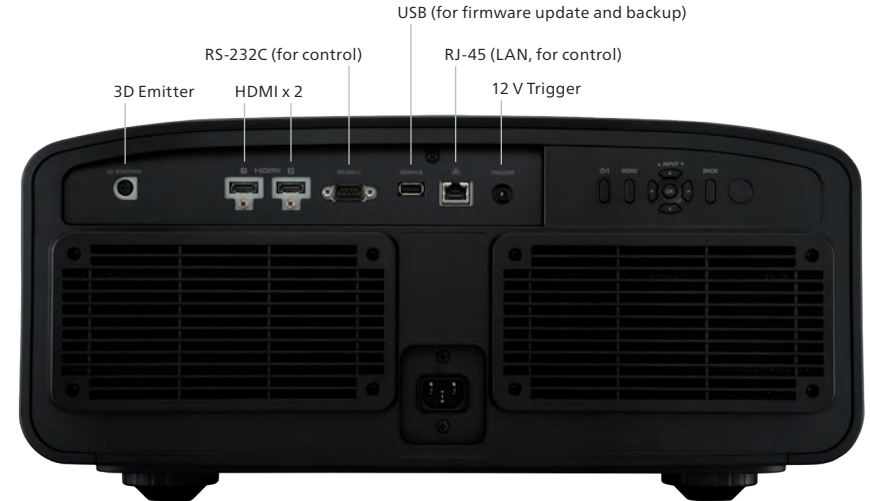

DLA-NZ700/NZ500

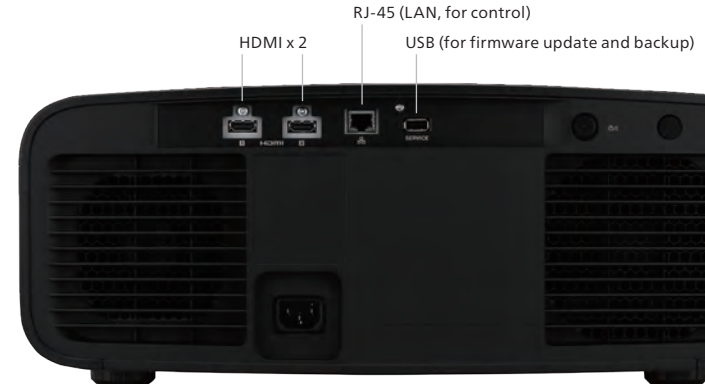

D-ILA The ART of PROJECTION A True Cinematic Experience



• D-ILA and e-shift are registered trademarks of JVCKENWOOD Corporation. • BLU-Escent Laser is a trademark of JVCKENWOOD Corporation. • FILMMAKER MODE™ logo and its trade name are registered trademarks of UHD Alliance, Inc. in the US and other countries. • HDR10+™ logo is a trademark of HDR10+ Technologies, LLC. • YouTube™ is a trademark or registered trademark of Google LLC. • ISF is a registered trademark of Imaging Science Foundation, Inc. • The terms HDMI, HDMI High-Definition Multimedia Interface, HDMI trade dress and the HDMI Logos are trademarks or registered trademarks of HDMI Licensing Administrator, Inc. • All other brand or product names may be trademarks and/or registered trademarks of their respective owners. • All pictures in this brochure are simulated. • Design and specifications are subject to change without notice. • Any rights not expressly granted herein are reserved.

Copyright © 2024, JVCKENWOOD Corporation. All Rights Reserved.

JVC

DISTRIBUTED BY

<https://www.jvc.com/>