

# ACOUSTEEL DAMP 100

Anti-vibration

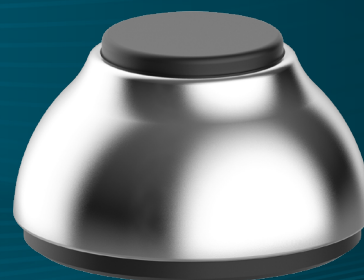

## DIMENSIONS

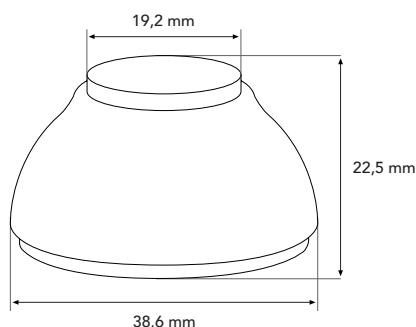

## DESCRIPTION

Optimize the sound experience of your audio system thanks to its vibration-absorbing technology, it effectively eliminates unwanted resonances to give you greater clarity and a more open sound.

Designed with high-quality materials, the Acousteel Damp 100 optimizes the performance of your audio system by eliminating distortion caused by parasitic vibrations.

Unleash the full sonic potential of your system and immerse yourself in your favorite music with clarity.

## MAX LOAD



↓ 30 KG MAX

## DESIGN

Finish : *Brass sand-nickel plated*

Structure : *Brass with silicon rubber*

## PRODUCT CODE



Finish : Brass sand-nickel plated

EAN : 3700795180983

SKU : NORACODAMP100

## MAXIMUM LOAD

With 4 units : 30 kg max

## USABLE DIMENSIONS

Diameter : 38,6 mm

Height : 22,5 mm

## CONDITIONNEMENT

Delivered in units of 4

Dimensions (W x H x D) : 173 x 50 x 173 mm

Net Weight (elements) : 258 g

Gross Weight : 483 g

